

Table of Contents

Welcome to Digatron	1
Instrument Functions	2 - 3
Battery Installation	4
Setting Limits and Warning Lights	4
Setting the Engine Limits and Delay Time	4
About Delay Time	5
Tach Calibration Number (RPM1)	5
Jackshaft Calibration Number (RPM2)	5
Setting the LED Warning Lights	6
PC Software: Set Up & Analysis.....	6
Recording	6
Moisture	7
Erratic Readings	7
Button Functions	8
Designators Defined.....	9
Repairs and Warranty	9

Welcome to Digatron

This manual covers the operation of your DT-50J instrument. This includes any 53 or 54 instrument. All 50 series instruments function the same; the only difference is the number of displays.

This book provides the information you need to quickly set up and use your instrument. It is a great reference guide.

If you are interested in learning more about how your Digatron instrument can help you analyze your engine functions and driving techniques, please visit our website, www.digatronusa.com, or phone (509) 467-3128.

Note: These instructions cover current versions. If you have an older version, and find the instructions don't exactly match, please contact Digatron at support@digatronusa.com or toll free at 866.344.2876.

Instrument Functions

A. Power/Record

Start Vehicle. Instrument turns on and starts recording automatically when a tach signal is received. Records for 2 hours, then records over oldest data.



B. Tuning at the Line

Set lights to turn on in increments that make tuning RPM at the line easier. See page 8 for instructions on setting warning lights. Lights can also be used as a tail light.



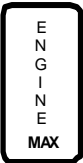

C. Starting a New Event at the Line

1.  Press 2 times to stop current Event and start a new one. This makes it easier to find the run during playback and downloading. Flashing : indicates the instrument is recording.
-





D. Overall Maximums

1.  Press and hold.
 2.  Press and release to cycle through up to three sets of engine data.
 3. Repeat steps 1 & 2 as desired.
-







E. Time Segments within Events

1.  Shows time for the last recorded time segment. Time segments are created with a manual store switch.
 2.  OR  Changes backward or forward one time segment. Displays flash for the shortest time segment.
 3.  Return to monitor / record mode.
-



F. Maximums by Time Segment (if using store switch)

1. Select a time segment. See [E. Time Segments](#).
 2.  Displays engine data, showing maximum values for this time segment. **2A.**  Displays time data. Press and hold to view Event number.
 3.  OR  Changes time segment backward or forward. Displays flash when your shortest segment is shown.
 4.  Return to monitor / record mode.
-

G. Playback

1. Select a time segment. See [E. Time Segments](#).
 2.  Press to view engine data.
 3.  Begins playback of selected segment. Pause and resume playback with each press.
 4.  If paused, steps through data in 0.1 second increments. If not paused, press and hold to fast forward.
 5.  If paused, reverse steps through data in 0.1 second increments. If not paused, press to reverse. Hold for fast reverse.
 6.  Press and release to cycle through up to three sets of engine data. **6A.**  Displays time data.
 7.  Press once to return to [E. Time Segments](#). Press again to return to monitor/ record mode.
-

H. Reset (clear memory)

1.  And  Press at same time.
 2.  Press when display flashes. Aborted if not pressed within 10 seconds.
-

I. Power Off

1.  Turns instrument off if it is not recording or receiving a tach signal.

OR

The instrument will turn off automatically if it does not receive any button presses or a tach signal.

Battery Installation

Two AAA batteries power the DT-50K. These allow the instrument to run for 40 hours with the backlight on and 150 hours with the backlight off. The instrument will display $\downarrow \square \downarrow$, signaling that the batteries are low, several hours before the functions becomes inaccurate.

To replace the batteries, remove the screw from the battery door on the back of the instrument. Replace the two batteries, observing battery polarity.

If your instrument is stored for a long period of time, remove the batteries.







Setting Limits and Warning Lights

Limits and warning lights warn you of conditions that could be harmful to your vehicle's engine. They should be set at levels that allow you to react to the visual warnings before engine damage occurs.

There are two ways to set your limits and warning lights:

- ◆ **With Your Instrument** (see below).
- ◆ **With Your PC**, download cable and configuration software (page 9).

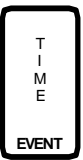
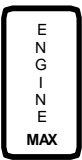
Setting the Engine Limits and Delay Time

-  From monitor/record, instrument enters Set Up menu. SEL will flash on display.
 -  OR  With SEL flashing, press either side button to enter Set Engine Limits.
 -  OR  Press either button to change the number being displayed. Hold the button to change the number faster.
 -  OR  Press either button to set next limit. Repeat steps 3 & 4 until all limits and calibration numbers are set.
 -  Press once to return to Set Up menu. Press again to return to monitor/ record mode.
-

Function limits are set in the following order: Temp1 (C1), Temp2 (C2), Tach (RPM1), Tach calibration number, Jackshaft (RPM2) limit, Jackshaft calibration number and delay time (minus any functions that you do not have). Also, if you are not using any functions on your instrument, set its limit to any number greater than 200.

About Delay Time (Optional, for Racing)

Some sanctioning bodies do not allow racers to use infrared beacon transmitters and receivers. If this is true for you, set your delay time to .1.

The delay time allows your instrument to ignore extra beacon signals at the track. Delay time is the time, in tenths of a second, that your instrument ignores beacon signals after receiving a signal. The delay time must be less than your best possible time between beacons, or the instrument will miss your beacon signal. Delay time is set in 5E1 of Set Up mode.

For example, if it takes you approximately 9 seconds to complete a run, set your delay number for 8 seconds. After your instrument receives its first beacon signal, it will ignore all signals for 8 seconds.

*Note: If you are not a racer, set your delay time to .1.

Tach Calibration Number (RPM1)

The Tach limit requires two separate parameters. The first is the maximum revolutions per minute (RPM) for safe engine operation. The second number, the Tach calibration, allows the instrument to display the correct RPM for your engine. The instrument divides the Tach input signal by the Tach calibration number. This number can be .5 to 31.

The most frequently used numbers are:

- 1 - for single cylinder 2 cycle and most 4 cycle motors
- 2 - for 2 cylinder 2 cycle and 4 cylinder 4 cycle motors









If you are unsure of the exact Tach calibration number for your engine, experiment. If your calibration number is currently set at 1 and the RPM displayed is double what it should be, set the calibration number to 2.

Jackshaft Calibration Number (RPM2)

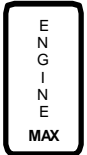
For the Jackshaft calibration number, enter the number of pulses per revolution that will be picked up by the sensor. A pulse is received when the sensor passes a ferrous metal object. If sensing more than one object, they must be evenly spaced. If using our collar, the number is four.

Setting the LED Warning Lights

Multiple warning lights can be set to the same function, but only one function can be set to a light. Warning lights can be used for adjusting your RPM at the line and as a tail light. They can also warn of high temperatures.

-  From monitor/record, instrument enters Set Up menu. SEL will flash on the display.
 -  SLL will flash on the display.
 -  OR  With SLL flashing, press either button to enter Set LED Warning Lights.
 -  Changes the function the light will correspond to.
 -  OR  Press either button to change the number being displayed. Hold the button to change the number faster.
 -  OR  Press either button to set next light. Repeat steps 4 - 6 until all lights are set.
 -  Press once to return to Set Up menu.
Press again to return to monitor/ record mode.
-

PC Software: Set Up & Analysis

All limits and warning lights can be set on your PC with our configuration software. This software also allows you to change which function is displayed in each window. Recorded information can be downloaded to a PC. The instrument must be in Monitor/Record mode, with no Tach signal when hooked up to a computer. **The instrument does NOT need sensors hooked up.** Software was included with your instrument. Download software updates from www.digatronusa.com. Attach the download cable to the white connector on your instrument. Attach the other end to any serial port on your PC. Then follow the computer's instructions.

Recording

The instrument records in sessions called Events (shown by an **E**), which start each time the instrument begins recording. Within Events, time segments (Laps, **L** on the display) are created with infrared beacon receivers and transmitters or with a store switch. To end an Event your engine must be turned off, the *Exit* button must be pressed, or the Tach must go below 200 RPM (this value can be changed on your PC).

Moisture

Your instrument is designed to be water resistant. We recommend keeping it as dry as possible. Please cover or remove your instrument before washing your vehicle. Digatron offers tach bags to help keep the instrument dry. If moisture does get inside the instrument, remove the endcap without switches and let the instrument air out in a dry environment. A hairdryer, on low power, can accelerate drying.

Erratic Readings

If the instrument encounters excessive electrical interference it will display ERR on the left side of the top display. The stored data might be invalid, and may need to be erased.

To erase your stored data, see Reset on page 4.

The ERR enunciator can also indicate an incorrect instrument or sensor installation. If your instrument is doing strange things, put it in Set Limits and check to see that the limits and calibration number(s) are still where you set them (see page 5).

Installing a resistance plug boot can normally solve electrical interference problems. We recommend using an NGK boot, # LB05EMH.

To avoid erratic readings:

- ◆ Keep your temperature and Tach leads separated by at least 3".
- ◆ Route the leads as far away from the coil as possible.
- ◆ Install the Tach lead on the plug wire at least 2" back from the plug boot. If you still have a problem, try a different location on the plug wire.
- ◆ Make sure your tach sensor ground wire is attached to bare metal.
- ◆ Replacing one or all of your sensors often solves this problem.

Please contact Digatron if your problem continues.

Button Functions

Lap (top, side button) (2) functions

- A. Displays time.
- B. Press and hold to show best time segment.

Engine (bottom, side button) (2) functions

- A. Cycles between up to three sets of data.
- B. Press and hold to show maximums and designators.

Power / Exit (2) functions

- A. Turns the instrument on and off.
- B. Exits Set Up and Playback modes.

← / Light (2) functions

- A. Press and hold to dim warning lights, and turn backlight on and off.
- B. Decreases values in Set Up and Playback.

→ / Set Up (2) functions

- A. Enter Set Up.
- B. Increases values in Set Up and Playback.

Play / Pause (2) functions

- A. Press for time, maximums and playback.
- B. Pauses and resumes playback.

Reset Instrument Erases recorded data and for troubleshooting.

- A. Press **Play / Pause** and **→** at the same time.
- B. Then Press **Play / Pause** within 10 seconds.

Designator Definitions

The following is a list of designators that can appear in the main part of your display:

- SEL select this to set your engine limits
- WLL select this to set your warning lights
- NONE displayed if the **Play** button is pressed and there is no recorded data
- OFF displayed if a warning light is set to not come on
- CAL displayed when setting the Tach or JS calibration number
- LoB displayed if your batteries are low
- RESET PLAY during a reset of memory, press the **Play** button to proceed with reset
 - CLR displayed if a reset of memory was successful
 - NO CLR displayed if a reset of memory is not successful
- LLP last lap time
- CLP current lap time
- BLP best lap time
- DIS lap distance
- HRS total hours
- ODO odometer
- REC displayed when recording and the **Play** button is pressed
- ENGINE displayed if the engine is on when trying to enter Playback
- PC displayed when the instrument is communicating with your PC
- CH1 CH2 Channel 1, Channel 2, which is temp1 and temp2 respectively
 - when shown on the top of a display, the function is over ranging. when shown on the bottom of a display, the function is under ranging

The following is a list of enunciators that can appear on the side of your displays. These show what function is in the display:

- | | | | |
|------|---------------------------|------|-------------------|
| RPM1 | tach | RPM2 | jackshaft RPM |
| CHT | cylinder head temperature | EGT | exhaust gas temp. |
| MEM | memory | ERR | error |

Repairs and Warranty Information

If you have any questions about the operation of your instrument, please call. One of our technicians will be happy to help you. Please have your instrument nearby to help while troubleshooting with the technician.

With the exception of physical damage and normal wear, there will be no charge for service required on internal parts for two years from date of purchase and for external parts for one year. Be sure to fill out and return your warranty card for our records. If we do not have a card on file for your instrument, you will be charged for repairs unless you can provide us with a proof of purchase date.

When returning an instrument for repair, please use the repair form found on our website or enclose a note indicating your return address, phone number and a detailed description of the problem. Send your instrument and sensors so that we can check the complete system.

Send repairs to:

Digatron LLC

120 N. Wall St. Ste 300

Spokane, WA 99201

www.digatronusa.com

Phone: (509) 467-3128 Fax: (509) 467-2952

5/7/2008